

Automatic data acquisition system

1. General description of automatic measuring system

First of all, measuring device consists of sensor (called as transducer or transducer) that is used as sensing device and output device (called as readout or data logger) that reads electrical signal transmitted from sensor, and these are linked via signaling cable.

Let me describe kind of output devices first..

1) Readout Unit (Single – purpose output device)

It is a kind of electric device that only reads and indicates data being transmitted from sensor, and called as Indicator as well.

2) Data Logger

Reads and displays data being transmitted from sensor, and an more intelligent device than Readout that has ability to stores data in the equipment itself, then transmits them to the notebook computer or PC, via RS-232 communication.

3) Data Acquisition System (Automatic measuring system)

It is general term of system that are installed for specific period of time on the site where needs semi-permanent measuring or real-time measuring frequency is high, and real-time displays received data with engineering units or tendency graphs and control them.

Various sensors would be installed at the site such as Piezometer, Inclinator, earth pressure cell and load cell.

Connect end points of each signaling cable of sensors to Multiplex Module(Abbreviation is MUX, and can connect a lot of cables directly) that collects data, then Multiplex Module composites communication network with Main Controller(called as Logger as well) to make possible to control on the main controller or PC.

It is general term that includes power supply part, operating software, enclosures, over voltage protection devices, alarm system, modem for wires/wireless communication, accessories for installing etc.

2. Description, Feature and Application of Automatic measuring system

1) Description

Automatic data acquisition system is available for monitoring at any time or at an interval time and for processing data on real-time after the instruments and environments related to measurement is entered. Data stores in memory of a controller and a computer.

A controller sends control command to multiplex modules after program is downloaded from a computer to a controller.

The controller stores in memory data retrieved from multiplex modules, and actuate an alarm by means of ringing bell or calling the designated cellular phone or the pager when values of limitation is exceeded. Data is uploaded from a controller to a computer and is displayed on the monitor.

The another communications to link the controller into the base computer are telecommunications via telephone lines and the radio frequency modem

2) Applications

- ◆ Logged data from instruments located in isolated, inaccessible or harsh environments.
- ◆ Measurement of instruments that telemonitoring is required
- ◆ Processed data by a computer
- ◆ Measurement of instruments that the frequency number in measuring is excessive.

3) Features

- ◆ High accuracy
- ◆ Continuous data acquisition and monitoring
- ◆ Quick transmission and saving of measured data

3. Components of automatic measuring system

The automatic acquisition system can be divided into applications, wired / wireless, and sensor types described below.

1) Computer

The computer runs the software, communicates with the controller. It also retrieves data from it and saves them.

2) Software

The software is used to enter instruments information and measurement environment, and to monitor data processing on realtime data and to display graph on the monitor.

3) Main Controller(=Data logger)

The main controller interfaces with a computer to be downloaded program and to be uploaded data retrieved from multiplex modules, and stores it..

4) Power Supply

The power supply provides power to multiplex modules. It inputs AC 110V or 220V and outputs DC 12V or 15V..

5) RS 232/485 Converter

Automatic data acquisition system

The RS 232/485 converter enables a controller to interface with a computer..

6) Bus Cable

The bus cable is available for connection a controller with multiplex modules and to send control command from a controller to multiplex modules and to send reading from multiplex modules to a controller.

7) VW Multiplex Module(VW MUX)

The VW multiplex modules are available for measuring a reading from the VW sensors.

They can measure the response all types of VW sensors.

8) EL Multiplex Module(EL MUX)

The EL multiplex modules are available for measuring a reading from electrolytic sensors.

They can measure the response all types of electrolytic sensors.

9) ER Multiplex Module(ER MUX)

The ER multiplex modules are available for measuring a reading from the electric resistance sensor like Foil strain gage or potentiometer sensor etc.

4. Classification of automatic measuring system

1) Classification by wires & wireless

For existing products, wires systems are applied generally, however, in recent years, wired + cell phone based wireless system is increasingly applied due to radical development of cell phone technology.

Also, we have been commercialized true wireless automatic system for the first time in the world.

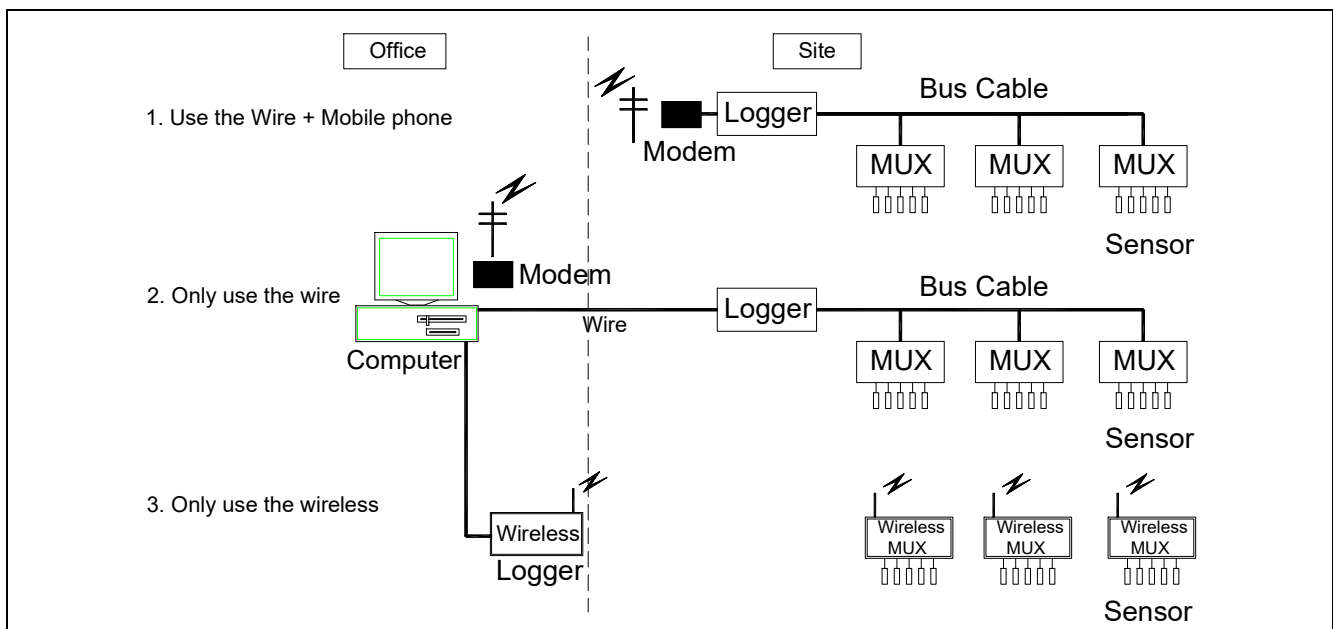

2) Classification by purpose

① Automatic measuring system for static measuring

Vibration – type sensor that transmits frequency signal is applied in the most of civil engineering sites because it is proper to semi-permanent measuring, electric resistance sensors that are capable of dynamic measuring(potentiometer, foil strain gage etc.) used by approx. 10%, and even electric resistance type sensor, they're used to mainly measure static characteristics except some purposes.

CR-10X(Campbell's in Canada), DT-515, 615(Data taker's in Australia), and our ARF-100(Wireless auto measuring system) are specifically designed to be used in static measuring system. It can normally obtain data 1 time per 1~2 seconds.

② Automatic measuring system for dynamic measuring

Generally, data loggers that are capable of obtain data 10 times per second to be classified as dynamic measuring system.

Dynamic measuring systems are mainly used to read accelerometer for identifying variation ratio of time vectors(Strong motion, seismic wave, etc.) and dynamically read measuring units that employ foil strain gage as a device that is used to test purpose.

- Dynamic Data logger for reading Foil strain gage
- Dynamic Data logger for read Accelerometer and Dynamic Data logger for read Piezo type accelerometer
- Dynamic Data logger For read servo-type accelerometer(Measure strong motion or earthquake waveform) are available.

Automatic data acquisition system

5. Problems of automatic measuring

Although a lot of companies talking about advantages of auto measuring, it is true that still has a lot of problems.

First of all, since civil engineering sites are target of auto measuring, a lot of noise would be caused by a lot of water, welding, motors and associated systems.

Main Purpose of auto measuring is to establish systems as soon as possible to operate without personnel to maximize economics, secure high reliable data to reflect them to the construction.

But in fact, when wired systems or wired + mobile phone based auto systems are installed, a lot cables should certainly to be installed at MUX, located next to the logger.

In this case, auto measuring is hard to implement from a moment of sensor installation, because breaking of wires to be occurs and wiring management spend so much time, due to operation of heavy equipments, frequent shift constructions in the environmental condition of civil engineering sites including, weak ground, harbors, structures and tunnels.

Also, maintenance personnel should be intervened due to frequent wiring damages, so meaning of unmanned automatization would be faded.

6. Considerations in automatic measuring

- ① Should not implement false advertisement for wired auto systems or wires + mobile phone based auto systems, identifying boundary of can dos and cannot dos, and should be pre-understood.
- ② Selection and installation of sensor is most important
Even products from reliable company, damaged cases due to immature installation or ignorance estimated to be more than 50%, so you should be familiar with user guide provided by manufacturers, then comply installing rules.
In fact, there are so many measuring devices that cannot rely on.
Although it is due to difficult situation, anyway, you should purchase reliable products after verifying several things.
Because selection and installation of sensors are critical in measuring for civil engineering, and local problems that occurs subsequently could be solves easily with solid fundamental
- ③ In such cases as dams or weak ground that need long-term measuring, overvoltage protector or lightning units should be connected to the end point of the sensor.
Sensors would be die if over-current flows through under effect of thunderbolt.
When connect to Data logger or MUX, you can obtain stable data by earthing shield wire to the place where water flows.
Even though look at so many measuring engineering makers, you cannot see the case that connect shield wire, even when read sensors with readout. If electric welding is carried out underneath, electricity could be flows through overall metal parts.
Data would be unstable when read them with Readout or auto systems at this time.
For this case, it is so frequent that output characteristics of the sensor proved to be bad.
- ④ Sealing kit should be used when signaling cables to be extended connected.
There are so many cases of extended connection at the engineering sites. Sealing kit made of epoxy should be used in these cases. It is predominant case that strip side end of signaling cable to connect by hand and finish with tape processing, whether there's water or not, and in this case, a lot of water could cause unstable data due to inferior insulation resistance, also, if water or humidity permeated a lot, sensor would be die due to short circuit.
Bad habit that should be necessarily corrected.
- ⑤ Development of specialty analysis software
Many manufacturers of well-known auto systems provide operating software only.
For instance, connect auto equipment that reads electric sensors to the computer and install software, only mV or mA would be transmitted, and even when equipment reading vibration-type sensors, mV or μsec signal would be transmitted only.
These manufacturers does not developed analysis programs because every devices in the measuring equipments being used to from grounding site to tunnels, bridges are different and application methods are different as well, so it is not so easy to compile, develop and operate so massive amount of programs.
Civil engineering makers should develop custom analysis software according to its type and purposes in the manner could be displayed as engineering units or trend graphs, based on low sensor data.
We are planning to develop operation & analysis software by 2006, based on the construction methods compatible with our product to classify them into bridge, tunnel, weak ground, structure, harbor and railway.
Existing some software is limited to the tunnel convergence monitoring, automatic ground horizontality, and analysis programs for vertical inclinometer. Presently, programs for bridges are developed.